

CHAIN BRACKET TUBE HOLDER

P/N: 8160

CHAIN BRACKET TUBE HOLDER

is designed for installation of Ø60-90 mm mounting tubes in two levels as an accessory to the Chain Bracket system.

FLEXIBILITY

Together with the Cue Dee Chain Bracket the Tube Holder can be installed on any pole from Ø110 mm up to Ø1070 mm. The Tube Holder is delivered as a set with two holders.

The Tube Holder is designed with adjustability in both horizontal directions; sideways and radially. This offers unique flexibility when installing and will allow for an exact vertical mounting even on conical monopoles.

Since Chain Bracket is designed with several profile elements around the pole you can easily install more than one tube around the pole in the same level by just adding Tube Holders.

QUALITY

All components are made of anodized aluminum and acid proof stainless steel which gives the support excellent corrosion resistance.

EASY ASSEMBLY

Installation is very easy thanks to its flexible design and that the holder is pre-assembled at delivery.

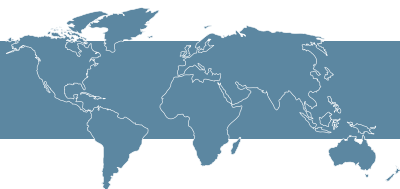
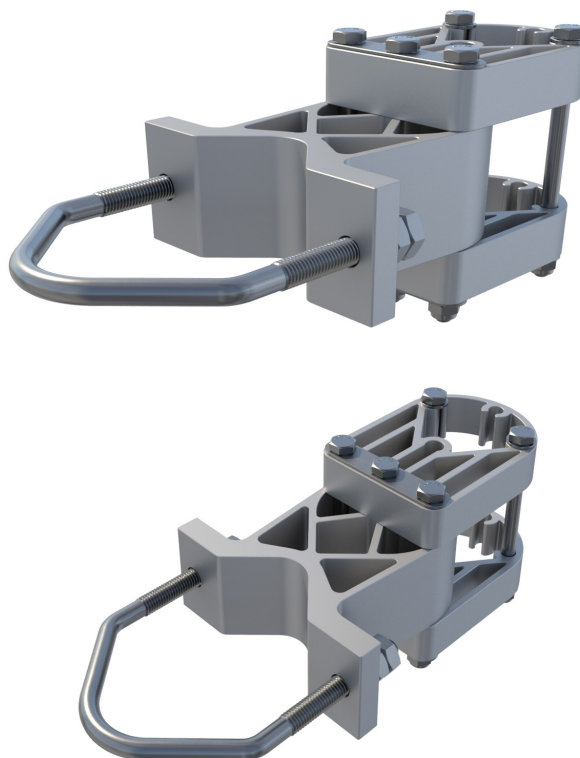

Quality Design

TECHNICAL INFORMATION

CHAIN BRACKET TUBE HOLDER

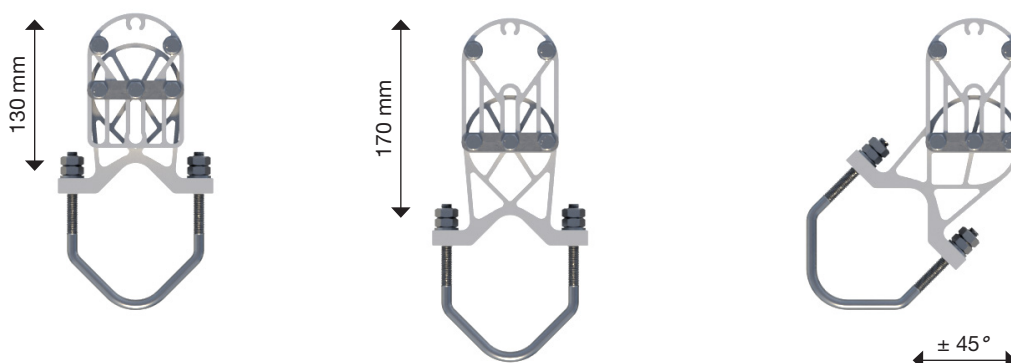

ORDERING P/N

8160

FUNCTION DESCRIPTION

Tube holder for Chain Bracket in two levels for installing Ø60-90 mm mounting tubes on any pole or monopole larger than Ø110 mm.
Distance between pole and mounting tube is adjustable 130-170 mm.

MOUNTING TUBE RANGE

Ø60-90 mm (Ø2,4-3,5 in)

MAX INCLINATION ADJUSTMENT

Linear 40 mm (1,5 in)
Rotational ± 45°

MECHANICAL DATA

Profiles: Aluminum, nature anodized 20µm
Plates: Acid proof stainless steel
Fasteners: Acid proof stainless steel

PERFORMANCE

OPERATIONAL WIND SPEED

MAX SIDE WIND AREA

MAX LOAD WEIGHT

km/h	m/s	mph	m ²	ft ²	kg	lb
240	67	150	0,4	4,3	150	330
210	58	130	0,5	5,5	150	330
180	50	112	0,7	7,5	150	330
150	42	93	1,0	11	150	330
120	33	75	1,5	16	150	330

PACKAGE DIMENSIONS

LENGTH

WIDTH

HEIGHT

WEIGHT

285 mm (11,2 in) 145 mm (5,7 in) 150 mm (5,9 in) 2,9 kg (6,4 lb)

ACCESSORIES

CHAIN BRACKET

MOUNTING TUBES, RUNNING METRE

P/N:	Product	P/N:	Tube: mm (in)
7685	Link Set (1 link)	1216	Ø60 x 3 (2,4 x 0,12)
7706	Basic Set #1 (3 links)	1217	Ø75 x 3,5 (3,0 x 0,14)
7664	Basic Set #2 (6 links)	1243	Ø75 x 5 (3,0 x 0,20)
7707	Basic Set #3 (9 links)	1242	Ø90 x 5 (3,5 x 0,20)

The verification is carried out in accordance with relevant parts of:

- EN 755-9:2008 Aluminium and aluminium alloys-Extruded rod/bars, tube and profiles
- EN 1999-1-1:2007 Eurocode 9: Design of aluminium structures – Part 1-1: General structural rules
- EN 1999-1-3:2007 Eurocode 9: Design of aluminium structures – Part 1-3: Structures susceptible to fatigue
- EN 1991-1-4:2005 Eurocode 1: Actions on structures – Part 1-4: General actions – Wind action

Compliance to ROHS 2 directives 2011/65/EU

