

# General Notes

## Fasteners:

### Stainless Steel:

Bolts: Stainless Steel Grade 80 (EN ISO 3506-1)

Nuts: Stainless Steel Grade 80 (EN ISO 3506-2)

### Galvanized:

EN 15048-1: Non-preloaded structural bolting assembly

Bolts: ISO 4017 8.8 (EN ISO 898-1)

Nuts: ISO 4032 8 (EN ISO 898-2)

Washers: ISO 7089 HV200

Hot Dip Galvanisation: ISO 10684

Torque Table [Nm]				
Thread Size	8.8 tZn Dry	8.8 tZn Oiled	8.8 tZn Waxed	A4-80
M12	N/A	N/A	N/A	76
M20	450	412	243	N/A

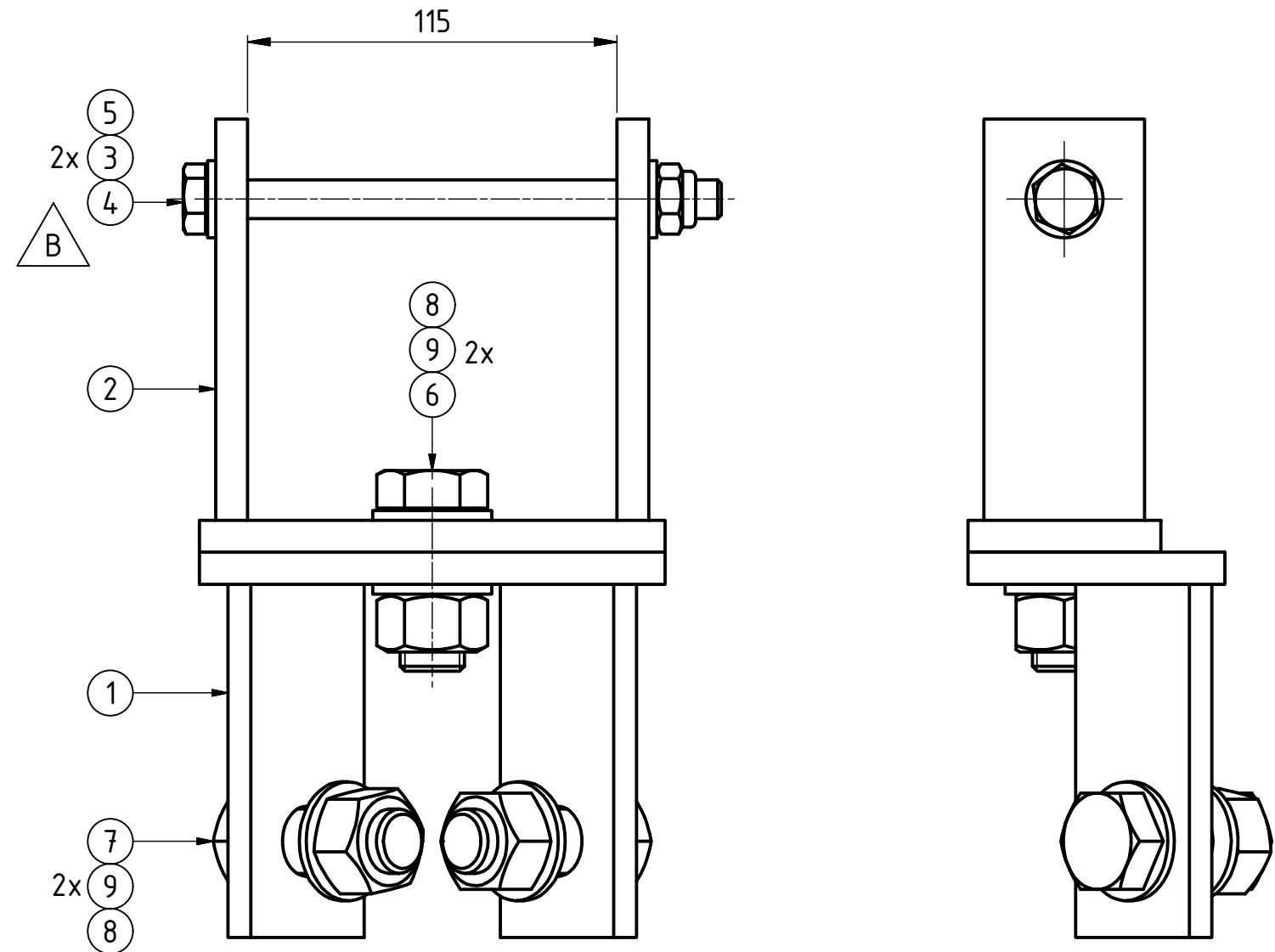
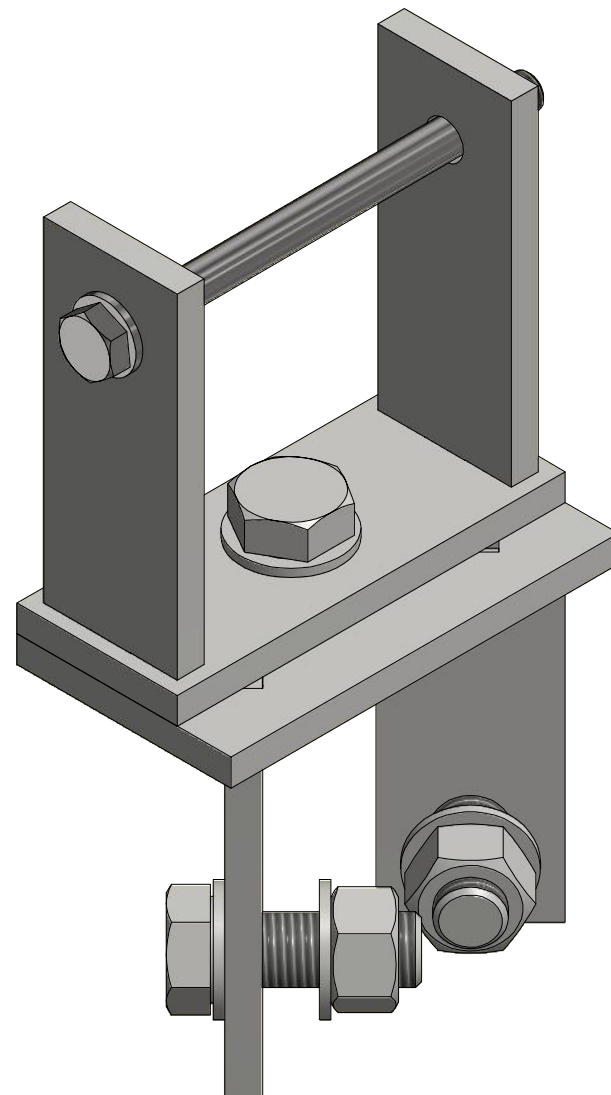

Revision History			
Rev	Description	Date	Checked
B	M12x160 was M16x170	2006-06-29	M.T

Item	Qty	Art. No	Part Number	Description/Material	Comments
9	6	1312	ISO 7089-20-200 HV-tZn	Plain Washers	
8	3	1399	ISO 4032-M20-8-tZn	Hexagon Nuts	
7	2	1357	ISO 4017-M20x55-8.8-tZn	Hexagon Head Screws	
6	1	1355	ISO 4017-M20x50-8.8-tZn	Hexagon Head Screws	
5	1	1406	DIN 985-M12 A4-80	Nylon Insert Lock Nut	
4	1	1331	DIN 931-M12x160 A4-80	Hex-Head Bolt	
3	2	1309	DIN 125-A 13 A4	Washer	
2	1	1743	CD 82390202	Tube Bracket	
1	1	1725	CD 82390201	Corner Bracket	

Phone: +46 934 153 10 Fax: +46 934 150 72 E-mail: info@cuedee.se	<b>CUE DEE</b> SE-915 93 Robertsfors, SWEDEN www.cuedee.se	Siska 58 Date: 2001-10-10 Name: P.P Title: <b>Corner Bracket Ballast Box</b>	Checked: 2006-06-29 Name: J-O.H Project:	Dwg. No.: <b>CD 823902</b> Art. No.: <b>1681</b> Revision: <b>B</b>
© - CUE DEE All Rights Reserved Information in this document is the exclusive property of CUE DEE. Reproduction in part or as a whole without the written permission of CUE DEE is prohibited		Status: <b>Released</b> Size: <b>A3</b>	Scale: 1 : 2 Weight: 4.4 kg	Sheet 1 of 1
File Name: C:\Vault\Designs\Antennfäste\Ballast Box\CD 823902.idw				